

# Solenoid Valves

The right solenoid valve for any job.

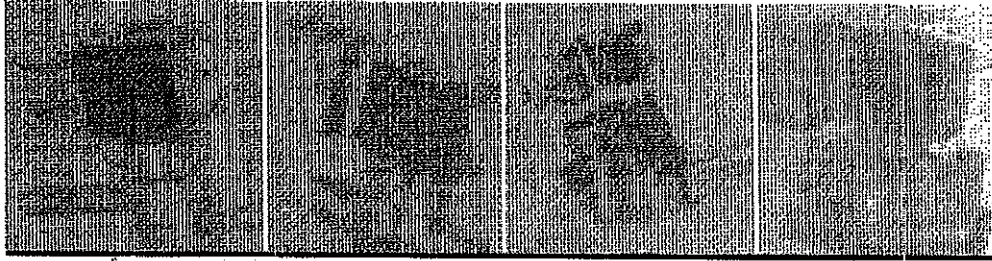

**Sporlan Solenoid Valves****Benefits**

- Molded coil for most sizes.
- Class "F" temperature rating — Coil types MKC-1, MKC-2, and OMKC-2.
- Extremely rugged, simple design — few parts.
- "E" Series may be brazed without disassembly.
- Tight closing through use of synthetic seating material.
- Can be used with most commercially available CFC, HCFC and HFC refrigerants because of high MOPD ratings. Consult Sporlan, Washington, MO for refrigerants not listed.
- Synthetic coated metal gaskets minimize external leaks.

**Contents****Sporlan Solenoid Valves**

SELECTION .....	3
CAPACITIES	
Liquid Line .....	4
Suction Line .....	6
Air & Water .....	19
Steam .....	19
Discharge Gas .....	6
SPECIFICATIONS	
Types A3, E3 and E5 Series .....	8
Types B6 and E6 Series .....	9
Types B9 and E9 Series .....	10
Types B10 and E10 Series .....	11
Types B14 and E14 Series .....	12
Types B19 and E19 Series .....	13
Types B25 and E25 Series .....	14
Types E35 Series .....	15
Type E42 Series .....	16
Built-In Check Valve Series .....	17
Industrial Solenoid Valves .....	19
GENERAL .....	21
DESIGN .....	22
CONSTRUCTION DETAILS .....	23
NET and SHIPPING WEIGHTS .....	23
ELECTRICAL SPECIFICATIONS .....	24
IDENTIFICATION .....	25
APPLICATION .....	27

**SOLENOID VALVES**

Installation and Service Instructions .....	Request Bulletin 30-11
3-Way Valves .....	Request Bulletin 30-20

*NOT FOR USE WITH HAZARDOUS OR CORROSIVE FLUIDS*

## Sporlan Solenoid Valves

## Features

### Experience

For more than sixty-five years Sporlan has provided sound engineering principles and craftsmanship to produce top quality solenoid valves and other flow control devices for the air conditioning and refrigeration industry.

### Continuing Research

Through continuing research Sporlan has produced constant product improvements as well as innovative designs. Examples of Sporlan's research developments include: synthetic coated metal gaskets; solenoid pilot control; synthetic seating; color coded lead wires; floating disc construction; extended solder type connections; Class "F" coil.

### Peak Performance

To assure peak performance, Sporlan uses thoroughly proven synthetic materials, resulting in lasting valve seat tightness. The high MOPD ratings of most Sporlan Solenoid Valves allow their use on any application using the common refrigerants.

### Unsurpassed Reliability

A combination of top quality materials used in both the internal and external construction ensures unsurpassed product reliability. This is verified by periodic accelerated life tests.

### Top Quality

Testing is performed during all phases of production followed by 100% testing for body and seat tightness, electrical characteristics and valve operation.

Sporlan packaging protects this quality for the ultimate user.

### Complete Line

Sporlan offers a complete line of solenoid valves to the industry. They are available in all capacities and connection sizes for air conditioning and refrigeration applications.

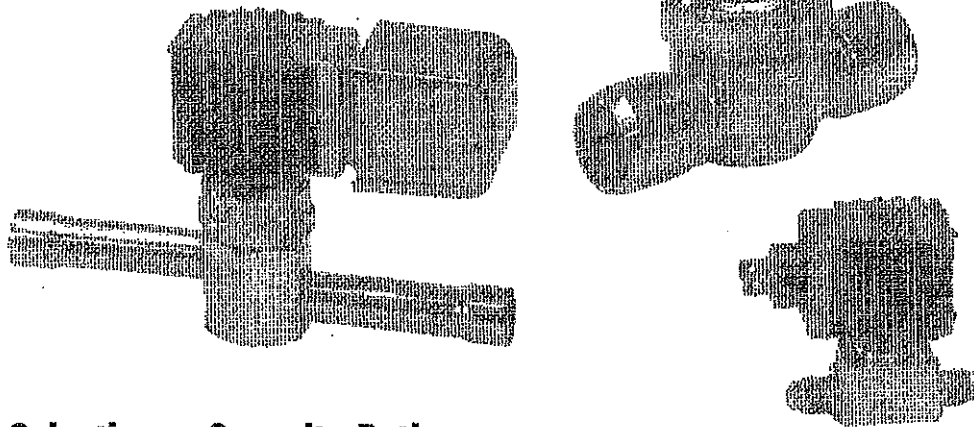

## Selection – Capacity Rating

The following information should be available when selecting a Sporlan Solenoid Valve:

- Refrigerant or fluid to be controlled.
- Capacity required.
- MOPD – Maximum Operating Pressure Differential required.
- Electrical specifications – volts and cycles.

With this information, the correct valve can be selected from the Selection Tables.

For Liquid Line capacity data, see Page 4 and 5 and individual specification pages.

For Suction Line capacity data, see capacity tables Page 6 and 7.

For Discharge Gas capacity data, see capacity tables Page 6 and 7.

All solenoid valves are tested and rated in accordance with A.R.I. Standard No. 760-2001.

# Liquid Capacity Selection Table

22, 134a, 401A, 402A

TYPE NUMBER	CONNECTIONS		TONS OF REFRIGERATION															
	Type	Size	22				134a				401A				402A			
			1	2	3	4	1	2	3	4	1	2	3	4	1	2	3	4
ASP1	---	---	19	21	0.8	15	18	20	0.9	1.6	19	21	0.6	0.9	12	14		
ASP1	---	---	33	35	1.5	26	30	34	1.6	28	33	37	1.1	1.5	21	24		
ASP1	---	---	57	64	2.7	46	53	59	2.9	49	57	64	1.9	2.7	38	42		
ASP1	---	---	93	104	4.4	75	87	97	4.7	81	93	104	3.1	4.4	62	69		
ASP1	---	---	128	143	6.0	104	120	134	6.4	111	128	144	4.2	6.0	85	94		
ASP1	---	---	182	203	9.5	147	170	189	9.1	158	182	204	6.0	8.5	120	134		
ASP1	---	---	280	314	13.0	226	261	292	14.0	243	281	314	9.2	13.0	185	207		
ASP1	---	---	478	535	22.2	386	446	499	23.9	414	479	536	15.7	22.2	315	353		
ASP1	---	---	830	937	36.3	662	774	871	39.0	710	831	938	25.6	37.3	545	615		
ASP1	---	---	111	123	56.7	91.5	104	114	61.0	98.0	112	123	48.4	54.6	73.8	81.4		

\* Do not use below 1 psi pressure drop, except Types A3 and E3 valves.  
Liquid capacities for Refrigerants 22, 134a, 401A and 402A shown in the above table are based on 40°F evaporating and 100°F liquid case

## REFRIGERANT LIQUID TEMPERATURE CORRECTION FACTORS

Refrigerant Liquid Temperature °F	40	50	60	70	80	90	100	110	120	130	140
R-22	1.33	1.27	1.22	1.17	1.11	1.06	1.00	0.94	0.89	0.83	0.77
R-134a	1.39	1.33	1.26	1.20	1.13	1.07	1.00	0.93	0.87	0.80	0.73

These factors include corrections for liquid refrigerant density and net refrigerating effect and are based on an average evaporator temperature of 40°F. For each 10°F reduction in evaporating temperature, capacities are reduced by approximately 1-12%.

Refrigerant Liquid Temperature °F	Refrigerant Liquid Temperature °F											
	40	50	60	70	80	90	100	110	120	130	140	
	Correction Factor	1.34	1.29	1.23	1.17	1.12	1.06	1.00	0.94	0.88	0.82	0.75

# Types A3, E3 and E5 Series

22, 134a, 401A, 402A, 404A, 407C, 502, 507

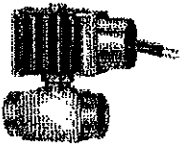

Type A3P1

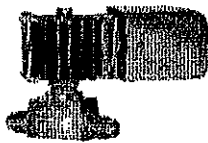

Type A3F1



Type E3S130  
or E5S130

UL and CE Listed  
Approved

## Application

**Types A3 and E3 series** are hermetic, direct-acting type solenoid valves primarily for refrigeration and air conditioning applications. The flow rate of the E3 and A3 are identical, therefore, the E3 may be freely substituted for the A3.

The **E5 series** are compact solenoid valves with pilot operated disc construction and are rated at 2.8 tons R-22 at 3 psi pressure drop vs. 1.6 for the A3S1. These valves **may be mounted horizontally, on their side or in a vertical line.**

The **Types E3 and E5 series** solenoid valves feature extended solder type connections as standard. One important benefit to the user is that all valves in the "E3" and "E5" series can be installed using either low or no silver content brazing alloy.

The MKC-1 coil is Class "F" temperature rated and is provided as standard, therefore a high temperature coil is not required for discharge service.

## Ordering Instructions

When ordering complete valves, specify Valve Type, Connections, Voltage and Cycles.

When ordering Body Assembly, specify Valve Type and Connections.

When ordering Coil Assembly ONLY, specify Coil Type, Voltage and Cycles.

**Example: MKC-1 120/50-60.**

## Dimensions - Inches

VALVE SERIES	TYPE	A	B	C	D/D'		E
					HYDR. DEPT. (ODM)	FLARE (ODM)	
A3	A3P1	1.88	0.44	2.20	-	-	-
	A3S1	1/4 ODF	2.07	0.28	2.36	0.44	-
		3/8 ODF	2.25	0.28	2.36	0.44	-
	A3F1	2.38	0.22	2.42	-	-	-
E3	E3S120	4.63	0.55	2.04	0.31	-	0.28
	E3S130	4.56	0.49	2.10		-	0.19
E5	E5S120	4.63	0.53	2.48	-	-	0.23
	E5S130	4.56					

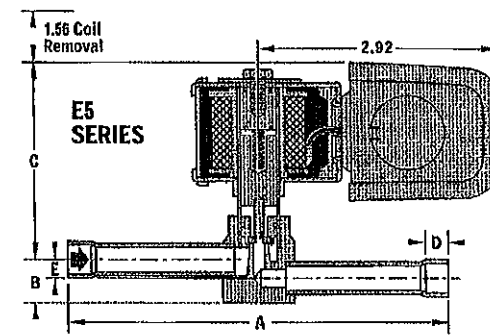
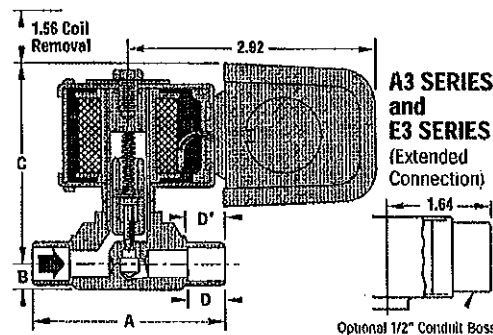

## Specifications - MKC-1 Coil

VALVE SERIES	TYPE	CONNECTIONS (Inches sizes shown in Blue will be 700 Series unless otherwise specified)	PORT SIZE (Inches)	MOPD (PSI)	NOMINAL LIQUID CAPACITIES (Tons of Refrigerant) at 100°F Saturated Vapor Pressure Drop (psi)										COIL RATINGS	
					22	134a	A1A	M2A	404A	407C	502	R01	STANDARD VOLTS/CYCLES	WATTS AC/DC		
A3	A3P1	3/8 NPT Female	.101	300	175	1.6	*1.2	1.3	1.1	1.1	1.5	1.0	1.0	24/50-60 120/50-60 208-240/50-60 120-208-240/50-60	10	15
	A3S1	1/4 ODF 3/8 ODM & 3/8 ODF - 1/2 ODM														
	A3F1	1/4 SAE Flare														
E3	E3S120	1/4 ODF X 1/4 ODF	.150	300	175	2.8	2.1	2.3	1.9	1.9	2.6	1.8	1.8			
	E3S130	3/8 ODF X 3/8 ODF														
E5	E5S120	1/4 ODF X 1/4 ODF	.150	300	175	2.8	2.1	2.3	1.9	1.9	2.6	1.8	1.8			
	E5S130	3/8 ODF X 3/8 ODF														

- Maximum rated pressure 500 psi.
- Dual voltage 4-wire coils, 120-208-240/50-60 are available at slight additional cost. For other voltages and cycles, consult Sporlan, Washington, MO 63090.
- See Pages 19 and 20 for water and steam valves.

- Available with conduit boss or junction box at no extra charge.
- For capacity at other pressure drops, see Pages 4 and 5.
- For mounting holes and/or bracket information see Bulletin 30-11.
- E3 and E5 series with mounting holes are NOT standard.

# Sporlan Solenoid Valves

# General

## Purpose

The primary purpose of an electrically operated solenoid valve is to control automatically the flow of fluids, liquid, or gas. Sporlan Solenoid Valves may be applied on a wide variety of applications.

## Basic Types

There are two basic types of solenoid valves. The most common is the normally-closed type, in which the valve opens when the coil is energized, and closes when the coil is de-energized. The other type is the normally-open valve which opens when the coil is de-energized and closes when the coil is energized. The operation of both types is discussed in the following paragraphs.

## Principles of Operation

Solenoid valve operation is based on the theory of the electromagnet. The solenoid valve coil sets up a magnetic field when electrical current is flowing through it. If a magnetic metal, such as iron or steel, is introduced into the magnetic field, the pull of the field will raise the metal and center it in the hollow core of the coil. By attaching a stem to the magnetic metal or plunger, this principle is used to open the port of the valve. When the electrical circuit to the coil is broken, the magnetic field will collapse and the stem and plunger either will fall by gravity or be pushed down by the kick off spring.

Some solenoid valves are designed with a hammer blow effect. When the coil is energized, the plunger starts upward before the stem. The plunger then picks up the stem by making contact with a collar at the top. The momentum of the plunger assists in opening the valve against the unbalanced pressure across the port.

Solenoid valves are also classified according to the "stem and plunger" action. The two types are discussed in the following sections.

## Direct Acting Solenoid Valves

With this type of valve, the stem and plunger assembly opens the port of the valve directly. This type of construction is limited to the smaller valves with port sizes of less than 1/4 inch. Sporlan Solenoid Valves of this design are the Types A3, E3, MA5A3, 180 Solenoid Pilot Control and W3P1.

## Pilot Operated

### Normally Closed Solenoid Valves

In a pilot operated valve, the stem and plunger assembly opens a pilot port. This releases the pressure on top of the disc, piston or diaphragm which then moves upward and opens the main valve port. Figure 3 illustrates the four phases of the operating cycle of a typical pilot operated valve. The operation is the same whether the valve is a disc, piston or diaphragm type.

Initially the pilot port and the main port are closed as shown in **A**. Pressure at the valve inlet is present on top of the disc as well, because of an equalizer hole drilled through the disc.

When the coil is energized, the stem and plunger assembly is lifted and the pilot port is opened — **B**. The stem and plunger assembly is centered within the coil by the magnetic field. The pilot port, if properly sized for the fluid to be handled, will relieve the pressure on top of the disc. Now the valve inlet pressure will act on a portion of the bottom of the disc, lifting the disc to open the main port — **C**. Once the port is open, the

Coil De-Energized  
Pilot Port Closed  
Main Port Closed

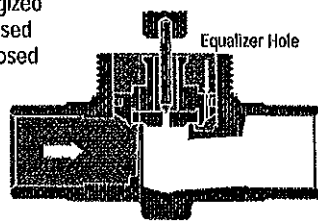

**A**

Coil Energized  
Pilot Port Open  
Main Port  
About to Open

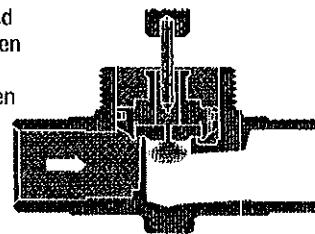

**B**

Coil Energized  
Pilot Port Open  
Main Port Open

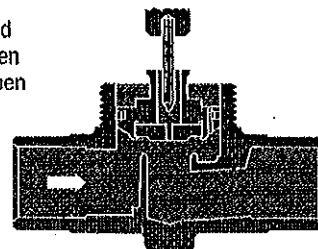

**C**

Coil De-Energized  
Pilot Port Closed  
Main Port Closing

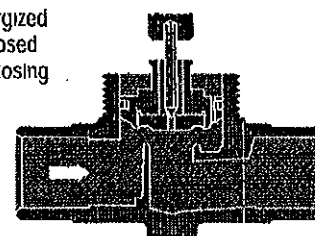

**D**

Figure 3

# General

# Sporlan Solenoid Valves

disc is held off the seat by the pressure difference across the port. When the coil is de-energized, the stem and plunger assembly drops, due to gravity or the kick off spring, and closes the pilot port. As shown in **D** the pressure above the disc is no longer vented to the downstream side of the valve. Fluid flow and pressure drop causes the pressure above the disc to be higher than below the disc, and the disc drops, closing the main port. In some valves the plunger is spring loaded and does not rely on gravity to close. All Sporlan Solenoid Valves except the A3, E3, W3, MASA3 and 180 SPC are pilot operated and employ either the floating disc, floating piston or floating diaphragm construction. The pilot operated valves require a very low, 1 psi, pressure differential for full operation.

Normally Open Solenoid Valves operate very similar to the normally closed type. The system pressure is utilized to open and close these valves.

The major difference in the normally open construction is that with the coil de-energized, a spring is used to push the stem and plunger assembly upward holding the pilot port open. This then allows the disc to rise, because of the pressure difference between the bottom and top of the disc, and permits flow to take place.

When the coil is energized, the stem and plunger assembly is pulled DOWN, closing the pilot port. The pressure on top of the disc then equalizes with the incoming pressure and the disc moves down closing the main port. The valve will remain closed as long as the coil is energized.

Direct-Connected Piston Assemblies, with the stem and plunger mechanically connected to the piston, are used on applications where the valve must be sized for very small pressure drop, such as on suction lines. While the pilot operated principle is still used to open the valve, the magnetic pull of the coil is utilized to hold the piston open, preventing possible pulsations. A disadvantage of the direct-connected type is the case where dirt prevents free piston movement and the plunger is unable to center itself in the coil. This will cause overheating of the coil and the danger of coil burnout is present. The "floating piston or disc" type permits independent operation of the plunger to allow a complete magnetic circuit regardless of the piston's position and thereby eliminates the possibility of coil burnout due to restricted piston or disc movement. For additional information, see Page 27, Suction Line Service.

# Design

## Maximum Operating Pressure Differential

The maximum pressure differential against which a solenoid valve can open is generally abbreviated MOPD. This is illustrated in Figure 4.

MOPD ratings are established at 85% of rated voltage and with a hot coil after its maximum temperature is reached. For any given valve and coil design, the factors that effect MOPD are voltage deviation and coil temperature.

## Synthetic Seating

Introduced by Sporlan in 1947, synthetic seating provides permanent seat tightness. Our experience in the use of these superior seating materials provides a reliable basis for durable construction best suited for various applications.

## Solenoid Coil

The interchangeability of solenoid coils is necessarily limited by considerations of the varying requirements of power and plunger movement. Nevertheless, only three coil sizes are required for the extensive line of Sporlan Solenoid Valves. Each coil is interchangeable between a number of valves within a given size range.

## Maximum Rated Pressure

Don't confuse the MOPD rating of a valve with the maximum rated pressure. The rated pressure of a solenoid valve is a design specification indicating the maximum pressure under which the valve should be applied. Actually, the valve must be able to withstand three times its maximum rated pressure and pass fatigue cycle tests, to qualify for listing by Underwriters' Laboratories.

## Manual Lift Stem

Occasionally, circumstances require that a solenoid valve be opened independently of the electrical power. Therefore, a manual lift stem is available on all valves from the B6 and E6 series up through the MA50 series.

Figure 4

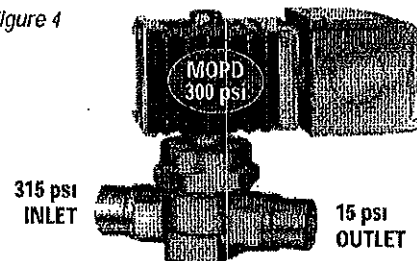

# Sporlan Solenoid Valves

# Construction Details

VALVE SERIES	PORT SIZE Inches	TYPE OF OPERATION	COIL VOLT	BODY MATERIAL	TYPE OF SEATING		STEM AND PLUNGER ASSEMBLY	PISTON DISC OR DIAPHRAGM						
					MAIN PORT	PILOT PORT								
A3P1	.101	Direct Acting	MKC-1	Brass	Synthetic to Metal	---	Stainless Steel	---						
A3F1					Metal to Metal									
A3S1														
E3														
E5	.150	Pilot Operated	MKC-2 and TOMKC-2	Brass Forging	Synthetic to Metal	Stainless Steel Pin to Synthetic Seat	Stainless Steel	Disc						
E6, ME6	3/16													
B6, MB6	9/32													
B9, MB9, OB9														
E9, ME9, OE9	5/16													
E10, ME10, OE10														
B10, MB10, OB10	7/16													
B14, MB14, OB14, E14, ME14, OE14														
B19, MB19, OB19, E19, ME19, OE19	19/32													
B25, MB25, OB25, E25, ME25, OE25	25/32													
E35, ME35, OE35	1			MKC-1 and TOMKC-1					Steel Casting	---	---	---	Piston	
B33, MB33, OB33				MKC-2 and TOMKC-2										
E42, ME42, OE42				1-5/16										
W3P1	.109			Direct Acting					MKC-1	Brass	---	---	---	---
W6P1	3/16	Pilot Operated	MKC-2	Brass Forging	Stainless Steel Pin to Synthetic Seat	---	---	Disc						
W14P2	7/16													
W19P2	19/32													
W25P2	25/32													
R183	9/16								MKC-1	---	---	---	---	Diaphragm
R184														
R246	3/4	---	---	---	---	---	---	---						

\*All "E" Series Valves have Copper Extended Solder Type Connections.

†Normally Open Solenoid Valve ONLY.

## Approximate Net and Shipping Weights†

VALVE SERIES WITH COIL	WEIGHT LBS.	
	NET	SHIPPING
A3, E3, E5, W3	1.0	1.2
B6, E6, W6	1.0	1.2
B9, E9	1.5	1.7
B10, E10	2.0	2.3
B14, E14, W14	2.0	2.3

VALVE SERIES WITH COIL	WEIGHT LBS.	
	NET	SHIPPING
B19, E19, W19	2.3	2.6
B25, E25, W25	3.1	3.4
E35	5.8	6.3
E42	10	12
R18, R24	2.3	2.8

† Weights may vary due to connection sizes, manual lift stem, coil voltage, etc.

# Construction Details

## Sporlan Solenoid Valves

Sporlan Solenoid Valves are constructed to insure long, trouble-free life. They employ proven design features for reliable performance on all applications. By using modern production equipment, Sporlan consistently provides top quality solenoid valves for air conditioning, refrigeration and other uses. Quality is maintained by strict quality control methods in all phases of production followed by detailed testing of every valve produced.

Extensive use of stainless steel, thoroughly proven synthetic materials and modern sealing methods along with top grade brass, bronze and semi-steel body materials, contribute to Sporlan's high quality product. The table on Page 23 lists the materials and construction details of Sporlan Solenoid Valves. Sporlan

reserves the right to change materials that improve the quality, performance and/or integrity of the product.

### Coil Construction

Sporlan solenoid coils are constructed with some of the finest materials available for electromagnet coil manufacture.

**Standard Coils** — The number 1 and 2 coils are wound on a molded Rynite<sup>®</sup> bobbin. The wound bobbin is then inserted into a mold in a transfer press and encapsulated with a thermoset polyester compound. The coil yoke is assembled afterward and the coils are identified as (O)MKC-1 and (O)MKC-2, US Patent No. 3,818,398. The thermoset polyester is moisture proof, fungus proof and meets military specifications.

# Electrical Specifications

Sporlan Solenoid Valve coils are available in many voltage and cycle ratings. The standard coils required are listed on the Specification pages for the various valves. Dual voltage, direct current (DC) and other alternating current (AC) coils are available for most valve types at slight additional cost. For other voltages and cycles, consult Sporlan, Washington, MO.

**Color Coded Lead Wires** — For ease of identification, coils are manufactured with the following colored lead wires:

24/50-60	Orange	208-240/50-60	Red
120/50-60	Blue	Dual Voltage	Black, Blue, Yellow, Red
208/50-60	Yellow		

All other coils are supplied with black lead wires.

### Wiring for Dual Voltage Coil

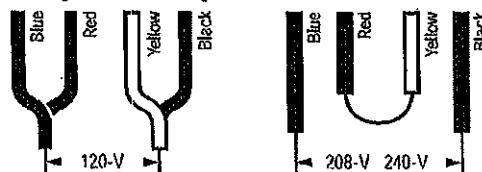

Leads on valves with a conduit boss are 18" long while coil leads on valves with a junction box are 6" in length.

**Junction Box** — All solenoid valves are available with either an integral junction box or a 1/2" conduit connection at no extra charge. All valves are automatically supplied with the integral junction box. If a conduit boss is required, it must be specified on the order.

All junction boxes are equipped with grounding screw provisions and marked in accordance with UL and CSA recommendations.

**Conduit Boss — Nema Rating** — The Standard (O)MKC-1 and (O)MKC-2 coil assemblies with conduit boss type yokes will satisfy Nema 4 and IP55 (Ram Tight) as well as Nema 1, 2, 3, 3R, 3S, 12 and 13.

### DIN Connector

(O)MKC-1E and (O)MKC-2E coils with Female DIN Connectors will satisfy IP65.

**Coil Interchangeability** — Only two coil sizes are required with the complete line of Sporlan Solenoid Valves.

The molded MKC-1 coil will fit the old style KC-1 coil. The molded MKC-2 coil will fit the old style KC-2 coil. Since the molded coils are a complete magnetic assembly, the old housing and related parts should be discarded when replacing the old KC-1 or KC-2.

# Sporlan Solenoid Valves Electrical Specifications

**Conversion from AC to DC Coils** — The conversion of a solenoid valve from AC to DC service varies with the valves construction and its principle of operation. Valve series A3, E3, E5, B6, E6, B9, E9, B10, B10, B14, E14, B19, E19, B25, E25, B33, E35, E42, all of the W series industrial valves and R-Series diaphragm valves can be converted from AC to DC service by changing coils. However, it is important to note that changing from AC to DC service does lower the valve's MOPD characteristics. This should be taken into consideration since the valve may not be able to open at these lower pressure ratings on some applications.

VALVE SERIES	RATING VOLTS/CYCLES	WATTS	CODE
A3, E3, E5, B6, E6, E35, R18, R24, W3, B5D, 8D, 12D, 10G, 16D	24/50-60, 120/50-60	10	MKC-1 and OMKC-1
	208-240/50-60		
	Dual 120-208-240/50-60		
B9, E9 B10, E10 B14, E14 B19, E19 B25, E25 B33, E42, 180 SPC	24/50-60, 120/50-60	15	MKC-2 and OMKC-2
	208-240/50-60		
	Dual 120-208-240/50-60		

## Identification

Listed by Underwriters' Laboratories Inc., Canadian Standard Association and CE Approved. UL File No. MH576 - CSA File No. LR19953

All Sporlan solenoid valves are identified by a valve nameplate, see Figure 5. This nameplate will indicate the valve type number, maximum operating pressure differential (MOPD) and maximum rated pressure (MRP). Any valves using the MKC-1, OMKC-1, MKC-2 and OMKC-2 will have their electrical specifications shown on the face plate of the coil assembly. See Figure 6.

### Ordering Instructions

The following table lists the standard coil configurations available. Other AC Voltages and Cycles may be available on special order.

When ordering any Coil Assembly, Specify Coil Size, Voltage and Cycles.

**Example: MKC-1 24/50-60**

### Coil Kits

MKC-1 and OMKC-1		
VALVE SERIES	RATING	VOLTS/CYCLES
A3	R183	
E3	R184	24/50-60
E5	R246	120/50-60
B6	8D	208-240/50-60
E6	12D	Dual 120-208-240/50-60
W3	10G	12 DC
W6	E35	24 DC

MKC-2 and OMKC-2		
VALVE SERIES	RATING	VOLTS/CYCLES
B9	B33	
E9	E42	
B10	180 SPC	24/50-60
E10	16D	120/50-60
B14	W14	208-240/50-60
E14	W19	Dual 120-208-240/50-60
B19	W25	480/50-60
E19		12 DC
B25		24 DC
E25		

\*OMKC Coils used only on normally open solenoid valves.

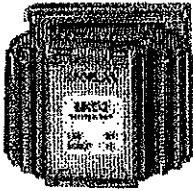

Figure 5

# Identification

# Sporlan Solenoid Valves

Figure 6



MKC-1, OMKC-1, MKC-2 and OMKC-2

## Nomenclature - A, B and W Series

O	D	M	B	25	S	2	*	S
Normally Open	Disc Type D - Direct Connected C - Built-In Check Valve	Manual Lift Stem	Design or Series A, B & W Series	Port Size in 1/32"	Connections P - Pipe F - SAE Flare S - ODF Solder	1 2 Coil Size	Overall Length	Spade Coil

THE ABOVE PREFIXES MAY BE ADDED TO BASIC VALVE TYPE NUMBER (B25S2) TO REQUEST SPECIAL FEATURES.

Normally open valves available in B9, E9 through E42 series only, and require OMKC-2 Coil Assembly. Add prefix D for direct connected assembly in MA32 and MA17A3 series. **Example: DMA32P3.**

## Nomenclature - E Series

O	C	M	E	10	S	2	5	0	*	S
Normally Open	Built-In Check Valve	Manual Lift Stem	Design Series	Port Size in 1/32"	Connections Solder	Coil Size	Connection Size in 1/8"	**Connections 0 - ODF x ODF 1 - ODF x ODM 2 - ODM x ODF 3 - ODM x ODM	Overall Length	Coil Connection S - Spade E - DIN 43650A

Q The MKC-1, OMKC-1, MKC-2 and OMKC-2 are fungus proof and meet MIL-1-631C.

2 The standard MKC-1 and MKC-2 are class "IP" rated.

\* No dash number indicates standard length. Dash numbers -1, -2, -3 etc. thru -18 indicates nonstandard longer or shorter overall lengths -19 thru -33 indicates other deviation from standard, contact Sporlan, Washington, MO.

\*\* Standard connections are ODF inlet x ODF outlet on "E" Series valves. Minimum quantities may be required for other connections.

The "E" series is identified by an expanded nomenclature compared to the "B" series. Continued is the system of valve identity based on port size. In addition, the "E" series identifies the connection size and type. The advantage of the "E" series nomenclature system is that it allows ease in valve identification of the standard line and can provide considerable information about special valves supplied to manufacturers. Details of the "E" series nomenclature are given above.

**Example:** MB10S250 is a valve with 5/16" port (10), manual lift stem (M), standard extended 5/8" ODF x 5/8" ODF connections (50) and standard overall length (no dash number).

Lengths and type of connections other than standard may be required to satisfy specific customer requirements. For connections and other special features consult Sporlan, Washington, MO. The specifications pages lists the standard length which applies regardless of type of end connection (ODF x ODF, ODF x ODM, ODM x ODF or ODM x ODM).

## Current and Superseding Valves

CURRENT VALVE TYPE	CURRENT COIL KIT	OBsolete VALVE TYPE	CURRENT COIL KIT
A3, E3	MKC-1	10, 162, 111	MKC-2
E5		—	—
B6, MB6	MKC-1	A6	MKC-1
E6, ME6		112, 11210, 11240	—
B9, MB9	MKC-2	A9, MA9, 14	MKC-2
E9, ME9		—	—
B10, MB10	MKC-2	A10, MA10	—
E10, ME10		120	—
B14, MB14	MKC-2	A14, MA14	MKC-2
E14, ME14		173, 172	—
B19, MB19	MKC-3*	A17, MA17, 43, 4304, 4303, 42, 4202	—
E19, ME19		—	—
B25, MB25	MKC-3*	A24, MA24, 53, 5304, 5303 52, 5202	—
E25, ME25		—	—
OB9, OE9	OMKC-2	—	—
OB10, OE10		—	—
OB14, OE14		—	—
OB19, OE19		—	—
OB25, OE25		—	—
OB33	OMKC-2	—	—
OE42		—	—
OE34	OMKC-2	E0B33, OE33	OMKC-2
E35, ME35	MKC-1	B32, MB32, MC32, 9001, 9005	MKC-3*
E35, ME35	MKC-1	(E)B33, (E)MB33, (M)E34	MKC-2
E42, ME42	MKC-2	EMB42S3	MKC-3*
180	—	1172, 1170, 1162	—
W3P1	MKC-1	—	—
W6P1		XKA	MKC-1
W14P2	MKC-2	XJQ	MKC-2
W19P2		4306-P, 4308-P	MKC-3*
W25P2		W24P3, 5306-P, 5308-P	
R183	MKC-1	W7P2	—
R184		—	—
R246		—	—

f Replacement coils no longer available.

\* Please contact Parker Aftermarket Customer Service for MKC-3 coils and associated parts.

## Sporlan Solenoid Valves

## Application

In the majority of cases, Sporlan Solenoid Valves are used for controlling the flow of refrigerants in liquid or suction lines, or in hot gas defrost circuits. They are equally suitable for many other less common forms of refrigerant control. These applications and other related topics are discussed in the following section. For applications not covered, consult Sporlan, Washington, MO.

### Liquid Line Service

The primary purpose of a solenoid valve in a refrigerant liquid line is to prevent flow into the evaporator during the off-cycle. On multiple evaporator systems, a solenoid valve may be used in each of the liquid lines leading to the individual evaporators.

Figure 7

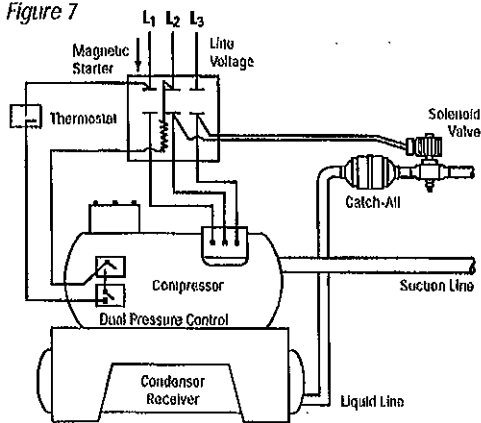

The application of a liquid line solenoid valve depends mainly on the method of wiring the valve with the compressor control circuit. It may be wired so the valve is energized only when the compressor is running. This type of application is illustrated in Figure 7.

Another application known as pump down control, uses a thermostat to control the solenoid valve. See Figure 8 for a wiring and valve location schematic. When the thermostat is satisfied, the valve closes and the compressor continues to run until a substantial

Figure 8

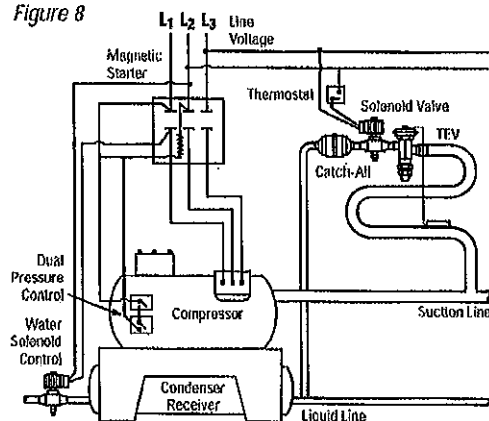

portion of the refrigerant has been pumped from the evaporator. A low pressure cutout control is used to stop the compressor at a pre-determined evaporator pressure. When the thermostat again calls for refrigeration, the solenoid valve opens - causing the evaporator pressure to rise and the compressor to start. This arrangement can be used on either single or multiple evaporators.

### Suction Line Service

There are several applications, particularly on suction lines, where pressure drops in excess of 2 psi cannot be tolerated. Therefore, only valves which are capable of opening at very low pressure drops are suitable for this type of use.

All Sporlan refrigeration solenoid valves are ideally suited for these special applications. They are capable of opening full at pressure drops of 1.0 psi.

For suction line capacities refer to the Tables on Pages 6 and 7.

### High Temperature Applications

Any valves using the MKC-1, OMKC-1, MKC-2 or OMKC-2 coil may be used on fluids or gases whose temperature does not exceed 240°F, while the valve ambient is 120°F.

**NOTE:** The MKC-1, OMKC-1, MKC-2 and OMKC-2 molded coils are satisfactory for use with hot gas bypass and hot gas defrost applications. Their unique molded rib surface radiates heat very rapidly and therefore a high temperature coil is not required in these two sizes.

# Application Sporlan Solenoid Valves

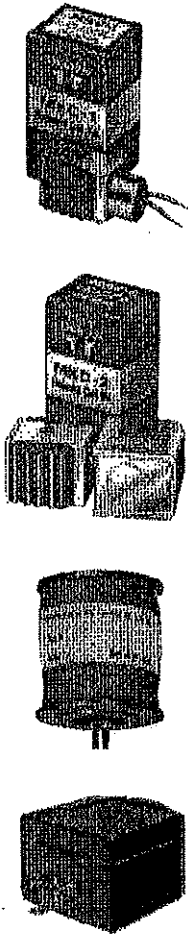

### Gas Defrost Service

There are several piping arrangements used for hot gas defrost systems, one of which is shown in Figure 9. A portion of the compressor discharge gas is passed through the solenoid valve into the evaporator. The solenoid valve may be controlled either manually or automatically for this duty.

Gas defrost valve selection requires a slightly different approach from the simple pressure drop versus tonnage. Be sure to consider the evaporator temperature correction factors shown at the bottom of the discharge gas capacities table in order to make certain that the valve selected does have adequate capacity.

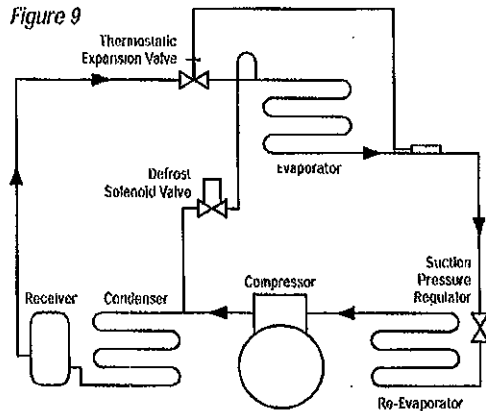

### Compressor Capacity Reduction Service

Sporlan Solenoid Valves may be used in conjunction with Sporlan Discharge Bypass Valves for capacity reduction service. For capacity information and further details on the Discharge Bypass Valves see Bulletin 90-40 or consult Sporlan, Washington, MO.

### Water Service

See Pages 19 & 20 — Industrial Valves.

### Filter-Driers are Essential

Dirt and other system contaminants present a problem for refrigeration and air conditioning controls. Since pilot operated solenoid valves operate with rather close tolerances, system cleanliness is imperative. The Sporlan **Catch-All® Filter-Drier** filters out minute particles of dirt and other foreign matter, thus protecting the valve.

Filtering is important on ammonia systems also. The replaceable core **Catch-All® Filter-Driers**, designed for ammonia use, acts as a scale trap to protect system components. Therefore, we recommend using a Sporlan **Catch-All® Filter-Drier** ahead of every solenoid valve on all refrigeration and air conditioning applications. Contact Sporlan before adding a **Catch-All® Filter-Drier** in the discharge line.

### Transformer Selection for Low-Voltage Control Systems

Many systems utilize low voltage controls, requiring the use of a transformer for voltage reduction, normally to 24 volts. The selection of a transformer is not accomplished by merely selecting one that has the proper voltage requirements. The volt-ampere (VA) rating is equally important. To determine the VA requirement for a specific solenoid valve, refer to the chart below. It should be noted, that insufficient transformer capacity will result in reduced operating power or lowering of the MOPD value.

If more than one solenoid valve and/or other accessories are operated from the same transformer, then the transformer VA rating must be determined by adding the individual accessories' VA requirements.

### Fusing

Sporlan Solenoid Valves are not supplied with fuses. Fusing should be according to local codes. We recommend fusing the hot leg of the valve wiring with fast acting fuses and the valve should be grounded either through the fluid piping or the electrical conduit.

COIL VOLTAGE	24 VOLTS 50/60 CYCLES		120 VOLTS 50/60 CYCLES		240 VOLTS 50/60 CYCLES		TRANSFORMER RATING VOLTS-AMPERES FOR 100% OPERATED MOPD OF VALVE
	CURRENT AMPERES		CURRENT AMPERES		CURRENT AMPERES		
	INRUSH	HOLDING	INRUSH	HOLDING	INRUSH	HOLDING	
<b>MKC-1</b> <b>OMKC-1</b>	1.9	.63	.39	.14	.19	.09	60
<b>MKC-2</b> <b>OMKC-2</b>	3.1	1.4	.60	.26	.31	.13	100

- All current values are based on 60 cycles.
- Volt-ampere ratings are based on inrush currents.
- Above values are based on the most severe conditions. — Consult Sporlan for coil characteristics on specific valve types.



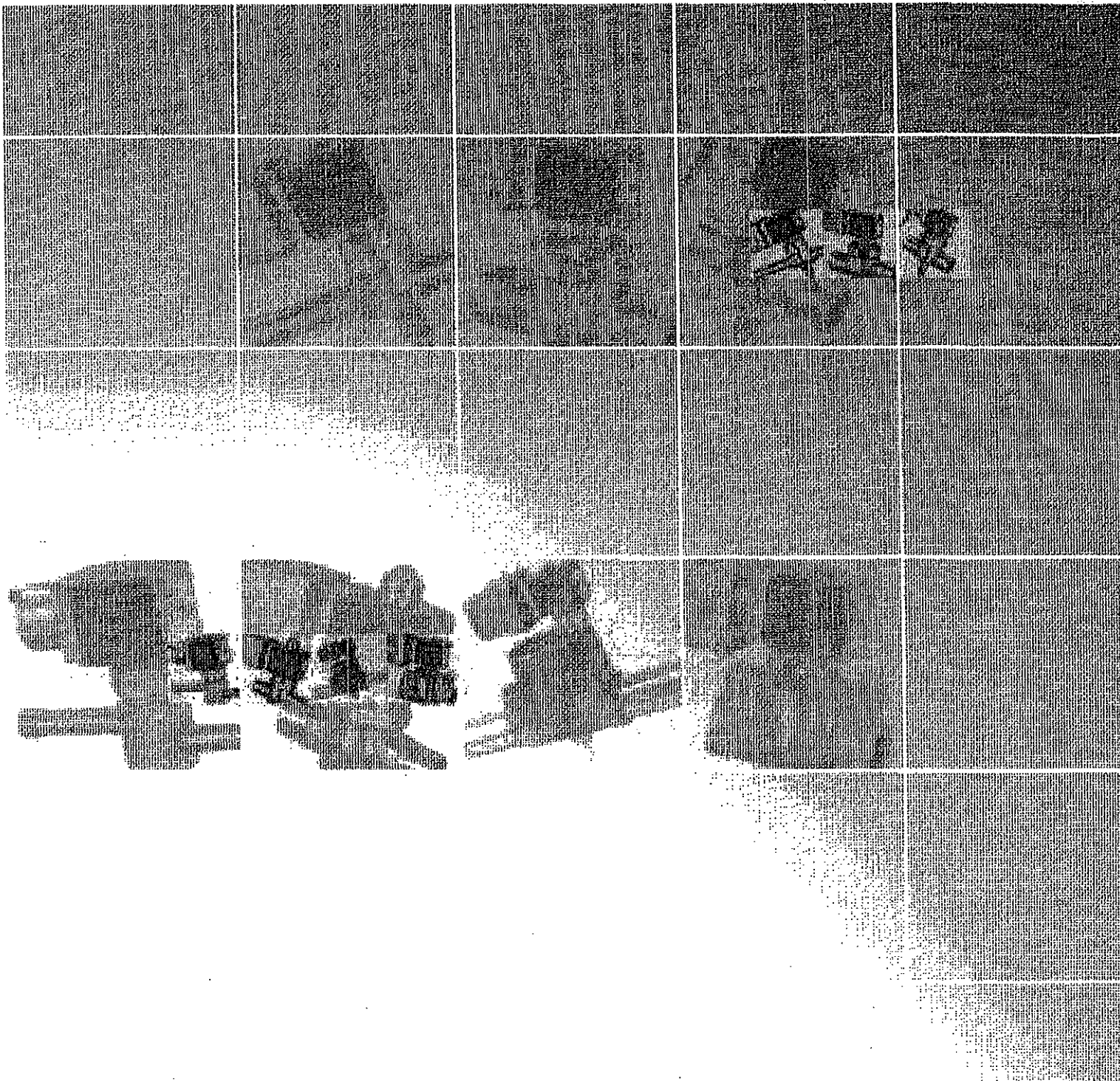
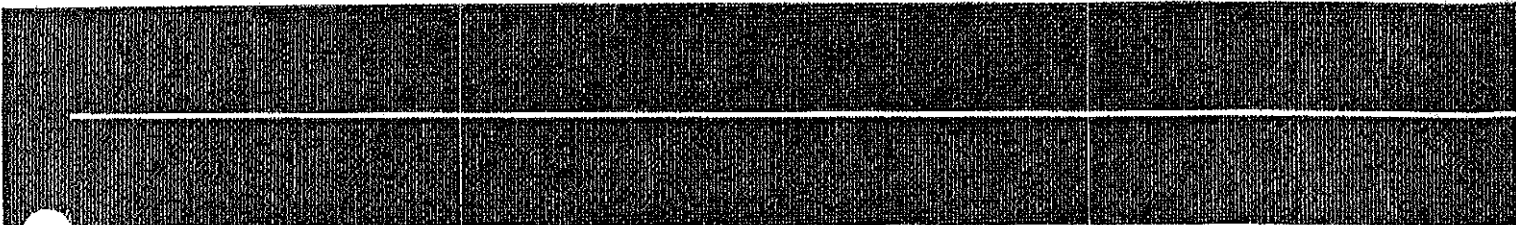

Sporlan Division  
Parker Hannifin Corporation  
206 Lange Drive  
Washington, MO 63090  
636-239-1111 • FAX 636-239-9130  
[www.sporlan.com](http://www.sporlan.com)

Printed in U.S. of A.

25-407