

The CZ-4 basic function is zone control. On a call for heating or cooling, the panel will accept the first call from any zone. Upon accepting this call, the CZ-4 will open the damper(s) to the zone calling, close the damper(s) to those areas not calling, activate the needed HVAC controls for heating or cooling, whichever is being called and not accept any calls for the opposite mode.

Any calls for the opposite mode will be locked out until the initial mode is either satisfied or a period of time has elapsed that is sufficient for the first mode to satisfy, a maximum of 20 minutes. A Patent Pending sequence determines the time the unit has been running or needs to continue to run in order to adequately provide conditioning for each mode. If a particular mode has already been calling for 20 minutes or longer and an opposite call comes in the CZ-4 will immediately drop the mode, enter the purge mode in order to dissipate the conditioned air into the zones calling before switching over to provide the new conditioning call to its zones.

When using the CZ-4 to control two stage heating and/or cooling, the second stage is controlled based upon time after the first stage call from the thermostat. When any zone calls the panel's built-in timer begins and after the set period of time elapses, the CZ-4 will also activate the W3 for Heating or Y2 for Cooling. The Second Stage Timer is adjustable from 5 to 23 minutes after the first stage calls. Once the second stage is on, it will continue to run until the first stage is satisfied or the limit setting is reached.

Once all zone thermostats are satisfied for heating and cooling, the CZ-4 can now accept Fan calls allowing Continuous Air Circulation (CAC) in those zones where the thermostat's Fan Switch is set to ON. These zone dampers will be Open while the dampers to the zones where the Fan Switch is set to AUTO will be CLOSED.

When all zone thermostats are satisfied for both Heating and Cooling and all Fan switches are set to AUTO position, the HVAC unit will be off and all zone dampers will return to a normally open position. Once a zone calls for heating, cooling or fan, the dampers to the calling zones remain open and dampers to the zones not calling will close.

### SET-UP FOR VARIOUS HVAC EQUIPMENT

The CZ-4 is factory set for conventional fossil fuel (oil or gas) single or two stage heating and cooling. The panel only needs to be configured when using with a conventional electric furnace or hydro-air system in order to bring the fan on with a call for heat, or when using with a heat pump.

Most all of the panel configuration is done by setting the DIP switches in the lower center of the panel. Below is shown their setting and functions.

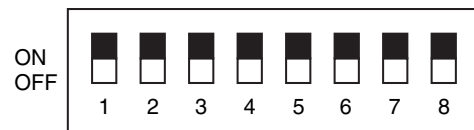

- HT PMP EQP** – Heat Pump Equipment – This switch changes the output of the HVAC Equipment terminals from conventional Heating and Cooling to a traditional Heat Pump Output. When OFF, a heat call activates the W1 output. When ON, a Heat call activates the Y1 output to bring on the compressor.
- FAN IN HEAT** – Activates the O output to turn the Fan on with a call for Heat. This is used for Heat Pumps, Electric Heat furnaces and Hydro-Air Systems. In the OFF position the CZ-4 will not activate the Fan in heating unless there is a fan call from one of the zone thermostats.
- STAT O TO W** – Switch is placed to ON when using Heat Pump thermostats that use an O terminal to activate the reversing valve in COOLING. The O on the thermostat is wired to W on the zone terminal in order to determine if the call is for heating or cooling. All zone thermostats must operate and be wired the same way.
- STAT B TO W** – Switch is used when using Heat Pump thermostats that use a B terminal to activate the reversing valve in HEATING. The B terminal on the thermostat is wired to W on the zone terminal in order to determine if the call is for heating or cooling. All zone thermostats must operate and be wired the same way.

#### 4. STAT B TO W (cont.)

**NOTE: Some OEMs use the B terminal as a transformer Common and not as the heating reversing valve. These thermostats will use the O terminal for the reversing valve and should be wired accordingly using DIP Switch #3. The B terminal will then be wired to the C terminal on the thermostat terminal block.**

5. **FAN IN PRG** – This switch keeps the fan running during the purge time in order to dissipate the conditioned air into the last zone(s) calling. Placing this switch to ON prevents the fan from turning off from the fan control in the HVAC Unit during the purge mode and coming back on moments later if another call is waiting. In OFF the fan will be controlled by HVAC Fan controls. This is desirable in residential applications to prevent cold drafts after heating by having the switch OFF.

6. **CNTL 1 – EMERGENCY HEAT** – This switch can be used to place all zones into the Emergency Heat mode. This switch would be used when single stage thermostats are used. **NOTE: There is no indication on the panel to show this switch is ON.**

7. **CNTL 2** – Future Use.

8. **CNTL 3** – Future Use.

One of the many features of the DIP switches is if at anytime the equipment is changed from single stage to heat pump or vice versa the thermostats do not need to be changed with the equipment change. Changing the DIP switch settings is all that is needed.

## WIRING

The CZ-4 is very simple to wire and requires only a minimum number of connections. The CZ-4 terminal blocks are screwless and all wires can easily be pushed into their respective terminal by depressing the button for each point and releasing once the wire is seated. To remove the wire, just press its button again and remove the wire.

**Zone Dampers** – The CZ-4 can power any 24VAC damper, either 2 wire or 3 wire. See specific wiring instructions with the damper or inside panel cover.

**Zone Thermostats** – The thermostats wiring will be for single stage (Y-G-R-W-C) or Heat Pump (Y-G-R-E-C and O or B). This wiring is shown on diagrams 1 for single stage and 3 for heat pumps.

**Equipment** – The HVAC equipment will follow wiring diagram 2 for single and two stage systems or 4 for heat pump systems.

WIRING DIAGRAM 1 – Single Stage Thermostat

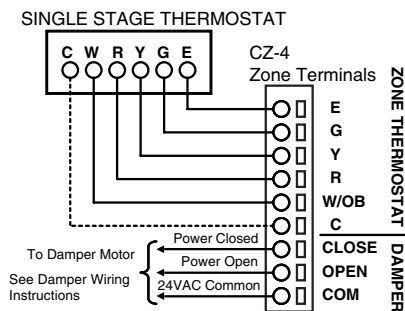

WIRING DIAGRAM 2 – Single Stage and Two Stage Equipment

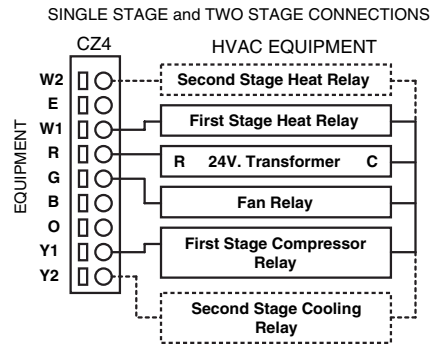

WIRING Diagram 3 – Heat Pump Thermostat

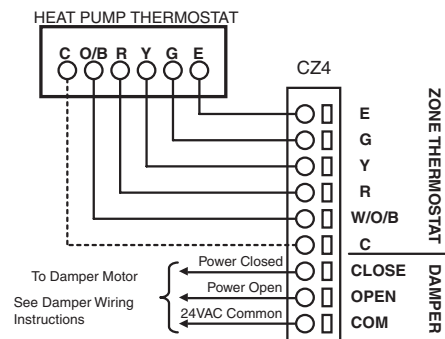

WIRING DIAGRAM 4 – Heat Pump Equipment

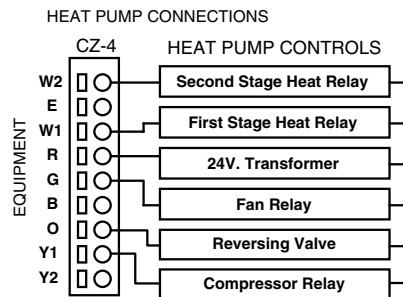

## STAGE TIMER

The CZ-4 has a built-in stage timer that eliminates the need and added cost of using two stage thermostats. On a call for either heating or cooling the timer begins. A minimum of 5 minutes, adjustable to a maximum of 23 minutes, can be set in order to activate the W2 or Y2 outputs after the first stage call.

The Stage Timer is marked 0 through 9 and each increment is indented as the dial is rotated. A minimum 5 minutes is set when the dial is set to 0. To calculate the stage timing the dial setting is multiplied by 2 and added to the base of 5 minutes. Example: Dial setting is  $3 \times 2 = 6 + 5 = 11$  Minutes for the Stage Timer.

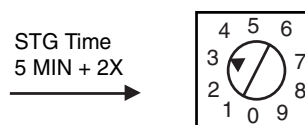

**PURGE TIME**

The CZ-4 has a built-in Purge Time after each call is satisfied and provides a minimum off time before another call is initiated. The Purge Time is set at 2.5 minutes after all calls for a particular mode are satisfied or when the Changeover Timer requires a changeover due to opposing calls.

After all calls are satisfied or the changeover timer activates, the Purge Timer begins and the heating or cooling, whichever was on, is deactivated. Typically the fan may be running during this time and the damper(s) to the last zone(s) calling will remain open to purge the conditioned air only into those zones that were calling for the conditioning.

DIP Switch 5 can be set ON to keep the Fan running during the Purge mode in order to prevent the fan cycling off and back on between modes. In the instance where the Fan staying ON may create a draft, and the frequency of opposite calls is minimal this switch can be kept to OFF.

The CLR PRGE button on the top left of the panel can be pushed to override the Purge mode and speed installation and checkout. This button is only active when the System LED is AMBER.

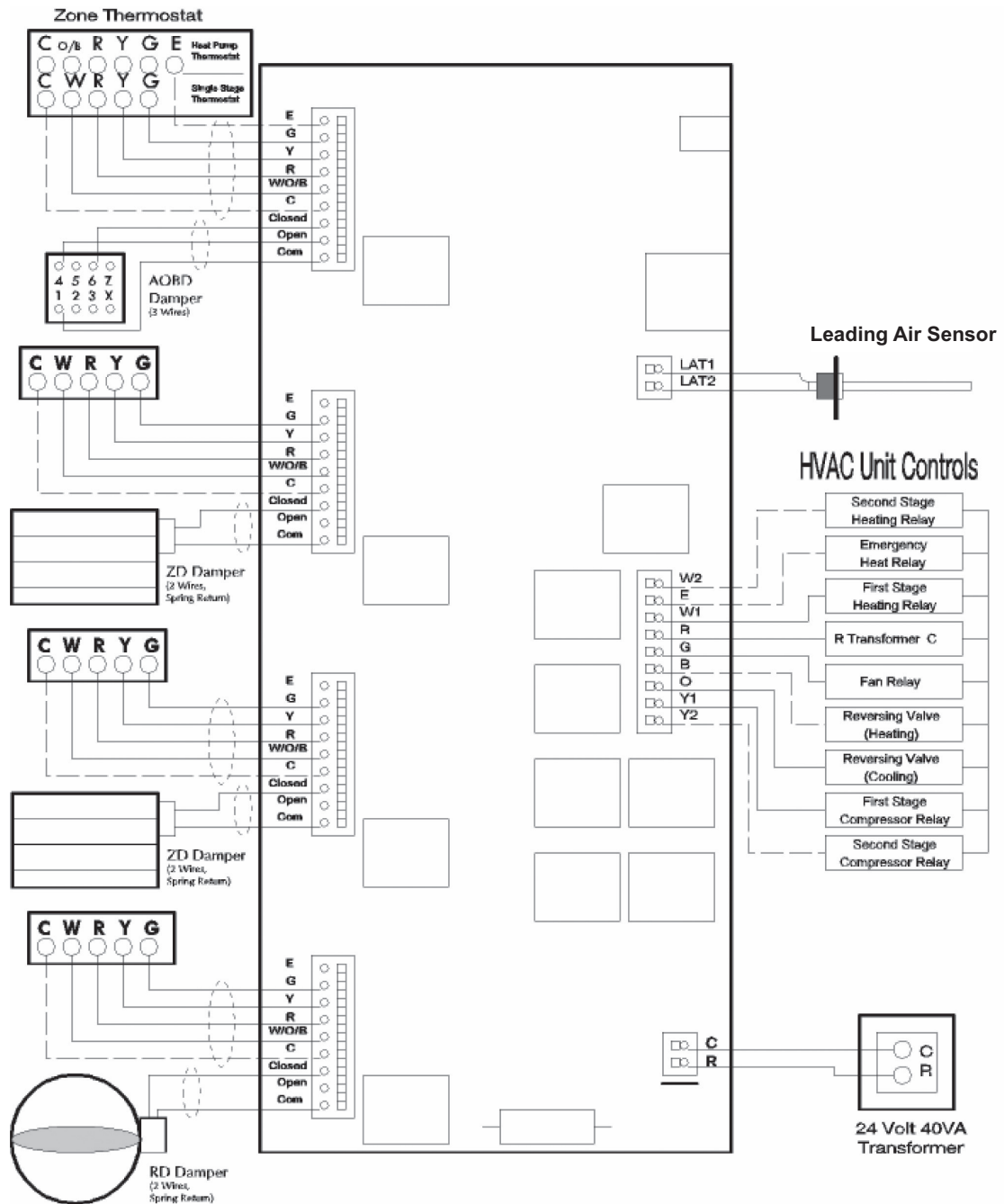

# CZ-4/CAZ-2 ADDING ZONES AND TROUBLESHOOTING

White  
Rodgers

## MINIMUM ON TIMER

The CZ-4 also has a minimum on time whenever the compressor operates in order to prevent frequent short cycling. Once there is a call for cooling or the compressor on a heat pump, the CZ-4 will hold that call for a period of 2 minutes.

## CHANGEVER TIMER

Whenever a call is made for either heating or cooling, the changeover timer is activated in order to track the amount of time heating or cooling is on. When an opposite call is made after a first call is existing the changeover timer calculates the amount of time the unit has already been supplying the first mode in order to determine how long it will hold off the opposite call. If an opposite call is made shortly after the first call, the opposite call may be held off for as much as 20 minutes. If the first call or subsequent calls for the first call mode has had that mode operating for up to 20 minutes already and an opposite call comes in after 20 minutes, the changeover timer will immediately recognize the opposite call, shutting off the current mode, enter the purge mode and automatically switch to the opposite mode.

The longer a call has been running, up to 20 minutes, the shorter the wait time will be for an opposite call. If a call is over 20 minutes and an opposite call is made the changeover will be immediate following the purge time. This intelligent changeover timing makes the CZ-4 unique to any other zoning system.

## CAZ-2

The Zone Panel can be added onto with Model CAZ-2. The CAZ-2 is available as a 2 zone adder panel and expands any CZ-4 panel to an almost unlimited number of zones. The CAZ-2 panel is connected by a 6 conductor RJ11 telephone cable. This makes wiring between the CZ-4 and CAZ-2 literally a snap.

## CHECKOUT

The CZ-4 has unique features that simplify the checkout of the system and has LED readouts that constantly indicate the system operation. Once 24 Volt Power is applied to the panel, the Green Power LED will illuminate. This will stay illuminated constantly when power is applied.

The System LED will provide several different indications based upon color and if it is flashing.

- Heat ON – RED
- Heat Limit – RED Flashing
- Cool ON – GREEN
- Cool Limit – GREEN Flashing
- FAN ON – AMBER
- PURGE – AMBER Flashing

Each zone has its own small Green indicator LED next to each zone relay. This light is lit when the specific zoning is calling for the mode shown on the System LED.

## TROUBLESHOOTING

The CZ-4 is a very simple control to troubleshoot, especially with the LED indicators. The only other device needed is a simple Volt/Ohm meter. Almost all problems can be traced to an external component or wiring to the CZ-4. While the CZ-4 has been designed to operate under extreme voltage conditions and is fuse protected, like any computer the micro-processor can hang up and not operate properly. For those instances a BOOT button has been installed that re-boots the micro-processor just like your computer. Pressing this button for a few seconds and then releasing it will allow the micro-processor to re-boot and in most all cases eliminate the problem. If not, the following procedure can help isolate the problem.



## ZONE(S) NOT CALLING

Each zone has a Green LED next to the zone relay when it is calling and that calling is being recognized by the CZ-4. If a zone is supposed to be calling and the Zone LED is not on, check for 24VAC across the thermostat terminal C and the Y, if a Cool call, W if a Heat call, or G if a Fan call. If there is no voltage here at the panel, the panel is not getting the signal from the thermostat. The problem is mis-wiring, a broken wire or a problem in the thermostat. To check the zone on the panel, place jumper from R to Y, R to W or R to G to see that the panel is operating properly.

## ZONE(S) WILL NOT SHUT OFF

If a zone will not stop calling, the Zone LED should still be on. Depending on the call, disconnect the Y, W or G wire from the terminal strip. The zone will drop out. Check the thermostat wiring for a mis-wiring or short that keeps the zone calling.

## DAMPER MOTOR CHECKOUT

To checkout the dampers, the panel provides 24VAC to the COM and OPEN when the damper is to be open and 24VAC to COM and CLOSE when the damper is to be CLOSED. When any zone is calling and its Green LED is ON, there is 24VAC across COM and OPEN. The only time a damper will close is when another zone is calling and its zone is not calling. In this instance there will be 24VAC across COM and CLOSE.